

Prior to following the instructions below, verify that this document is the latest version in use. The latest version can be found at www.barsplice.com.

INSTALLATION INSTRUCTIONS

No. 14, No. 18 ZAP SCREWLOK TYPE 2 AND EPOXY COUPLERS ON GRADE 60 REBAR AND UNCOATED ASTM A 615, GRADE 75* REBAR [U.S. METRIC GRADE 420 (UNCOATED GRADE 520)]

Slide the **ZAP SCREWLOK** coupler over one of the rebar ends until the rebar touches the positive center stop of the coupler, as shown in Figure 1. Do not under-insert, as shown in Figure 2. If the coupler is specially supplied **without** a center stop or if the center stop is removed, measure and mark the rebar for one half of the coupler length ($L/2$) before inserting it into the coupler per Figure 3 and Chart 1.

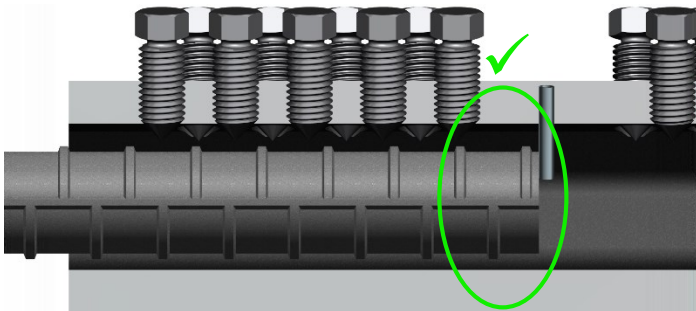

Figure 1. **Correct** Rebar Insertion Depth

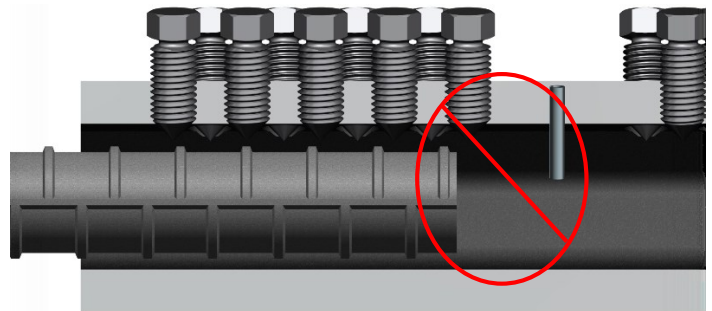

Figure 2. **Incorrect** Rebar Insertion Depth

Using an **impact wrench** and a **socket "S"** per Chart 1, tighten the twist-off screws starting **at the end** of the coupler and working your way **down one row toward the middle** of the coupler. Tighten each screw until the head of the screw **twists off**. See Chart 1 for approximate twist-off torque. After all the heads have been twisted off on the first row, repeat the procedure down the second row, starting at the end and working your way toward the middle of the coupler.

For illustration purposes only.
See **CHART 1** on page 2 for number of screws and twist-off torque.

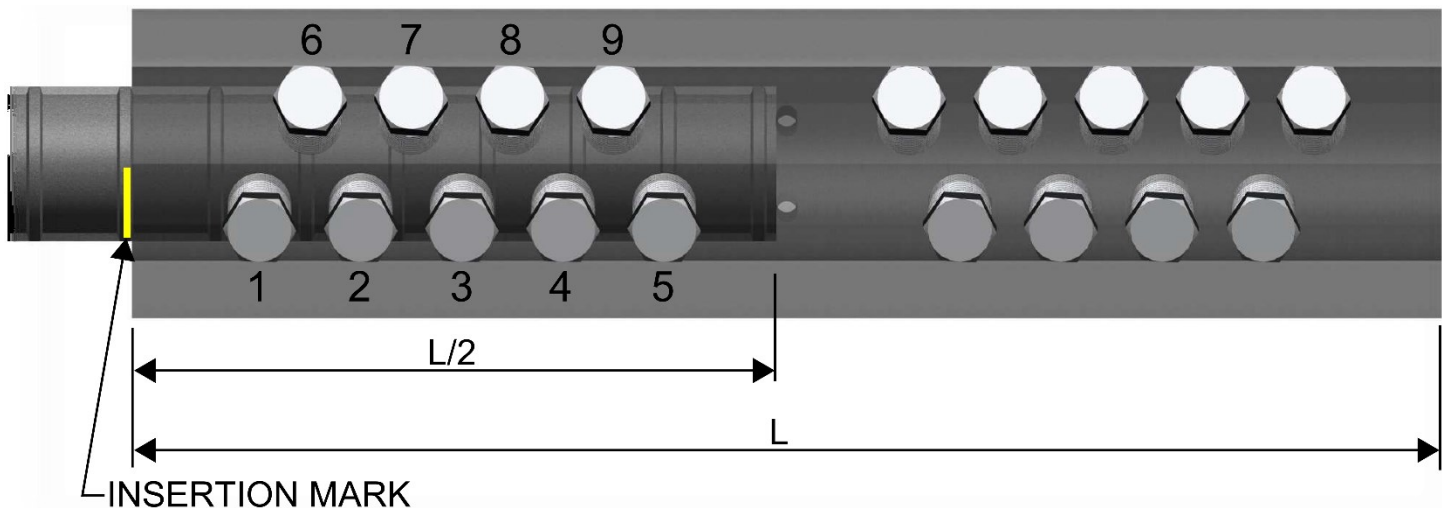

Figure 3. **Correct** Tightening Order, 1ST Side

*CONTACT BPI FOR APPROPRIATE COUPLERS TO CONNECT DUAL-CERTIFIED GRADE 75/GRADE 100 LOW CARBON CHROMIUM STEEL BARS THAT CONFORM TO ASTM A1035. CONTACT BPI FOR TRANSITION SPLICES.

Once the screws for the first rebar have been tightened down and heads twisted off, **insert the other** rebar into the coupler until it butts up **against the center stop**. If the coupler has no center stop, insert the second rebar until it butts up **against the first rebar** per Figure 4. In the **same order** as the first side, tighten the screws **down one row** until the heads break off working from the end of the coupler toward the middle of the coupler. Then repeat the procedure down the second row, working from the end of the coupler toward the middle.

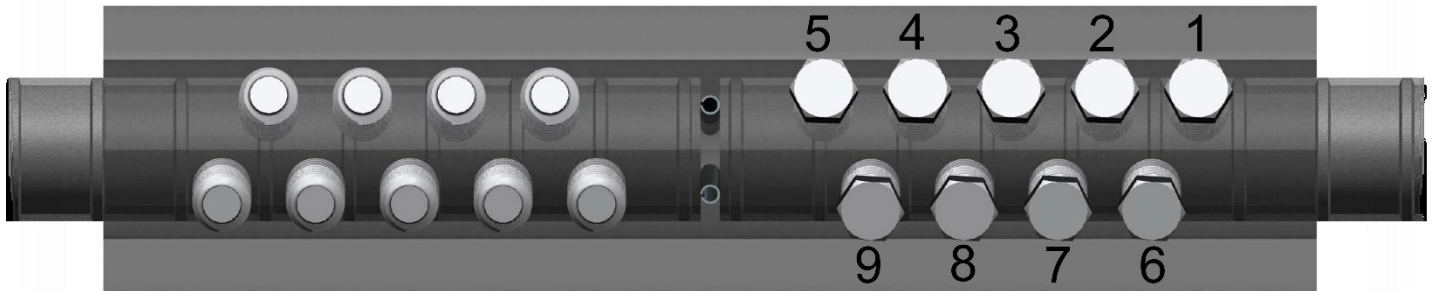

Figure 4. **Correct** Tightening Order, 2nd Side

DO NOT USE THESE COUPLERS IN CONJUNCTION WITH REBAR WHICH IS SMALLER THAN THE INTENDED BAR SIZE. **KEEP COUPLERS CLEAN AND KEEP THREADS RUST FREE, PER FIGURE 5. STORE COUPLERS IN A CLEAN, DRY PLACE UNTIL READY TO INSTALL. RUST IN THE THREADS PRIOR TO ASSEMBLY, PER FIGURE 6, IS UNACCEPTABLE BECAUSE IT COULD RESULT IN LOWER PERFORMANCE OF THE ASSEMBLED SPLICE.**



Figure 5. Clean **Acceptable** Coupler



Figure 6. **Unacceptable** Rust in Coupler Threads

CHART 1

REBAR SIZE US [metric]	APPROXIMATE COUPLER LENGTH "L" (in.)	½ COUPLER LENGTH "L / 2" (in.)	NUMBER OF SCREWS PER BAR	IMPACT SOCKET SIZE "S"	AVERAGE SCREW TWIST-OFF TORQUE "T" (ft-lb)	MINIMUM IMPACT WRENCH WORKING TORQUE (ft-lb)
#14 [43]	18	9	10	¾	350	1000
#18 [57]	29 ½	14 ¾	21	¾	350	1000

▼ Example of suitable impact wrench is Ingersoll Rand, IR 290

CAUTIONS AND SUGGESTIONS

1. For best installation and performance, try to adjust the orientation of the coupler or rebar so that the rebar deformations are in full bearing contact with the wedge shape of the coupler body, opposite of the screws.

PREFERRED REBAR ORIENTATION

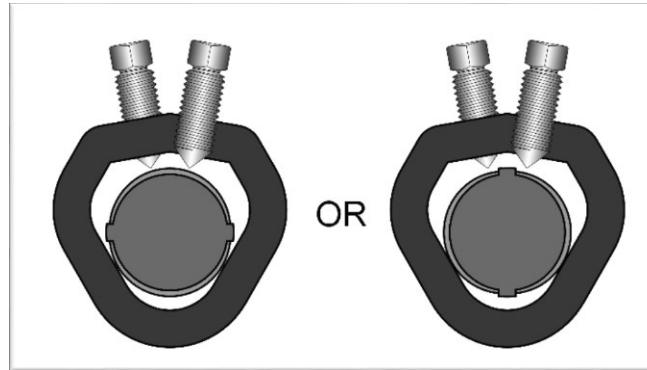

2. Follow the torque order described. Do not use any other torquing order.
3. For **best performance** and **ease of installation**, use a high quality 1 inch drive pneumatic **impact wrench** (▼ such as Ingersoll Rand IR 290) and suitable impact socket. Make sure the impact wrench is rated to achieve at least the minimum impact wrench working torque specified in **CHART 1** to avoid stalling. The **air supply** hose and fittings should have an inside diameter of **¾ inch or 1 inch**. The towable air compressor should be large enough to provide **100 psi** (7 bar) gauge pressure & deliver a minimum air flow at load of **60 cfm**.
4. Each screw should normally take 4 – 8 seconds for the head to twist-off. If each screw takes more than 10 seconds to twist-off, then there is either a restriction preventing enough air flow to reach the impact wrench or the impact wrench is worn out/undersized and needs to be serviced/replaced. Examples of restrictions are the air line is too small, underrated air compressor, gauge pressure at air compressor set too low, hose fittings too small, underrated impact wrench, outside temperature too low for air compressor or impact wrench to function properly.
5. **Do not use** an open-ended wrench or an adjustable wrench because of the risk of rounding-out the hexagon head prior to reaching the torque needed to twist off the head.
6. Prior to assembly, straighten excessively bent rebar ends so that proper wedge contact is made between rebar and coupler. BAR ENDS should be straight to within ⅛ inch in 18 inches. For curved rebar with a diameter that exceeds 54 feet, a bar end straightness check is not necessary. If needed, grind-off large shear lips that prevent proper insertion of rebar into coupler.
7. If removal of the center stop is necessary, use a hammer and punch or large nail to tap out the roll pins (2) in the coupling body.
8. Replace missing screws immediately with BPI special screws only. **DO NOT ALLOW THREADED HOLES TO RUST.**
9. If bars are corroded, removal of rust/corrosion on the bar ends must be performed to the same degree as that required to bond with concrete prior to installing the Zap coupler. Testing of old or severely corroded bars is recommended to ensure the integrity of the adjoining bars and compliance to design requirements. Performance statements of Zap couplers are based upon the use of ASTM **A615 / A706** Grade 60 rebar or uncoated ASTM A615 Grade 75 rebar.
10. For Epoxy Coated ASTM A775/A775M rebar, use pre-epoxy coated ZAP SCREWLOK EPOXY SERIES couplers supplied by Barsplice Products, Inc. Touch-up coating damage and the sheared surfaces of screws with a suitable epoxy patching kit after assembly. **DO NOT APPLY FUSION-BONDED EPOXY POWDER COATINGS TO UNCOATED COUPLERS or HEAT THE COUPLERS FOR THE PURPOSE OF EPOXY COATING. DO NOT HOT-DIP GALVANIZE UNCOATED COUPLERS. DO NOT ALLOW ABRASIVE BLAST MATERIAL TO COME INTO CONTACT WITH UNASSEMBLED THREADS.**
11. In all cases, consider your own **personal safety**. Make sure you are securely positioned and that you will not slip or fall during installation.