



Most Widely Accepted and Trusted

# ICC-ES Report

## ESR-3517

ICC-ES | (800) 423-6587 | (562) 699-0543 | [www.icc-es.org](http://www.icc-es.org)

Reissued 10/2016  
This report is subject to renewal 10/2018.

**DIVISION: 03 00 00—CONCRETE**  
**SECTION: 03 21 00—REINFORCING STEEL**

**REPORT HOLDER:**

**BARSPLICE PRODUCTS INC.**

**4900 WEBSTER STREET**  
**DAYTON, OHIO 45414-4831**

**EVALUATION SUBJECT:**

**ZAP SCREWLOK® TYPE 2 MECHANICAL CONNECTOR SYSTEM**  
**FOR SPLICING STEEL REINFORCING BARS**



Look for the trusted marks of Conformity!

*“2014 Recipient of Prestigious Western States Seismic Policy Council (WSSPC) Award in Excellence”*



*ICC-ES Evaluation Reports are not to be construed as representing aesthetics or any other attributes not specifically addressed, nor are they to be construed as an endorsement of the subject of the report or a recommendation for its use. There is no warranty by ICC Evaluation Service, LLC, express or implied, as to any finding or other matter in this report, or as to any product covered by the report.*



**ICC-ES Evaluation Report****ESR-3517**

Reissued October 2016

*This report is subject to renewal October 2018.*[www.icc-es.org](http://www.icc-es.org) | (800) 423-6587 | (562) 699-0543

A Subsidiary of the International Code Council®

**DIVISION: 03 00 00—CONCRETE**  
**Section: 03 21 00—Reinforcing Steel****REPORT HOLDER:****BARSPLICE PRODUCTS INC.**  
4900 WEBSTER STREET  
DAYTON, OHIO 45414-4831  
(937) 275-8700  
[www.barsplice.com](http://www.barsplice.com)**EVALUATION SUBJECT:****ZAP SCREWLOK® TYPE 2 MECHANICAL CONNECTOR  
SYSTEM FOR SPLICING STEEL REINFORCING BARS****1.0 EVALUATION SCOPE****Compliance with the following codes:**

- 2012 *International Building Code*® (IBC)
- Other Codes (see Section 8.0)

**Property evaluated:**

Structural

**2.0 USES**

The Zap Screwlok® Type 2 Mechanical Connector System is used to mechanically butt-splice deformed steel reinforcing bars in reinforced concrete construction. The system complies with Section 12.14.3.2 of ACI 318 (ACI 318 as referenced in Section 1901.2 of the IBC) for use as tension and compression mechanical connections of ASTM A615 Grades 40, 60 and 75 or ASTM A706 Grade 60 deformed steel reinforcing bars. The system used to splice ASTM A615 Grade 40 and 60 bars and ASTM A706 Grade 60 bars complies with Type 2 mechanical splice requirements of Section 21.1.6.1 of ACI 318 for use where Type 1 or Type 2 mechanical splices are specified by the IBC and ACI 318.

**3.0 DESCRIPTION****3.1 General:**

The Zap Screwlok® Type 2 Mechanical Connector System is available in two types: Standard and Transition. The Standard coupler is used to splice reinforcing bars of equal size up to No. 11 with a single row of screws and to splice No. 14 and No. 18 equal size bars using double rows of screws (see Table 1). The Transition coupler is used to splice reinforcing bars of two different sizes (see Table 2).

**3.2 Materials:**

The Zap Screwlok® Type 2 Mechanical Connector System (coupler) consists of a shaped steel sleeve with converging sides, a central stop pin, and a series of steel screws with cone-shaped points. The sleeve is produced from ASTM A519 Grades 1018 to 1026 steel with minimum yield strength of 36,000 psi (248 MPa) and a minimum tensile strength of 60,000 psi (420 MPa). The screws are produced from ASTM A322 Grade 4140 steel. The system is used for splicing two deformed reinforcing bars having either equal or unequal diameters and having yield strength of 40 ksi (300 MPa), 60 ksi (420 MPa) or 75 ksi (520 MPa). These deformed reinforcing bars must comply with ASTM A615 or A706. The reinforcing bars, except for #14 and #18, may be coated in accordance with A767 (zinc-coated) or A775 (epoxy-coated). Dimensional data is presented in Tables 1 and 2. Couplers are illustrated in Figure 1.

**4.0 DESIGN AND INSTALLATION****4.1 General:**

The Zap Screwlok® Type 2 Mechanical Connector System (couplers) is installed at the jobsite. A reinforcing bar is inserted into one coupler end to the center stop. The screws are then tightened from the coupler end inward towards the center of the coupler and the reinforcing bar is engaged to the coupler by indenting the bar surface and wedging the bar into the converging sleeve sides through tightening of the screws. Screws must be tightened to the torque value shown in Tables 1 and 2, as applicable, at which point the screw heads shear off. After the first bar is secured, the other reinforcement bar is inserted into the opposite coupler end to the center stop. The screws are then tightened in the same manner as for the first bar.

All measurements pertaining to minimum bar spacing distance and concrete coverage requirements described in the IBC and ACI 318, must be measured from the outside of the sleeves.

As Type 2 splices, the couplers may be installed in any location within a member, for all seismic design categories, provided the reinforcing bars are limited to Grade 40 and 60 reinforcing bars and comply with Section 21.1.5.2 of ACI 318.

**4.2 Special Inspection:**

Special inspection must be provided at the jobsite as required by Section 1705 of the IBC. In addition to verifying placement of steel reinforcing bar splices, the special inspector must verify the grade and size of reinforcing

bars; reinforcing bar embedment; coupler identification; field preparation of components; and assembly of the components resulting in the spliced bars.

## 5.0 CONDITIONS OF USE

The Zap Screwlok® Type 2 Mechanical Connector System for splicing reinforcing steel bars, as described in this report, complies with, or is a suitable alternative to what is specified in, the code indicated in Section 1.0 of this report, subject to the following conditions:

- 5.1 The couplers must be identified and installed in accordance with the applicable code, the manufacturer's instructions and this report. In the event of conflict between this report and the manufacturer's instructions, this report governs.
- 5.2 Special inspection must be provided in accordance with Section 4.2 of this report.
- 5.3 The minimum concrete cover must be in accordance with the IBC and must be measured from the outer surface of the coupler.
- 5.4 Splice locations must comply with the applicable IBC requirements and must be noted on plans approved by the code official.
- 5.5 For structures regulated by Chapter 21 of ACI 318 (as required by IBC Section 1905.1), to splice reinforcing bars resisting earthquake-induced flexure, axial force, or both, in special moment frames, special structural walls, and all components of special structural walls including coupling beams and wall piers, with the Zap Screwlok® Type 2 Mechanical Coupler System, mill certificates for reinforcing bars must be submitted to the code official as evidence that the steel reinforcing bars comply with ACI 318-11 Section 21.1.5.2.

## 6.0 EVIDENCE SUBMITTED

Data in accordance with the ICC-ES Acceptance Criteria for Mechanical Connector Systems for Steel Reinforcing Bars (AC133), dated December 2012.

## 7.0 IDENTIFICATION

The couplers, including the screws, are packaged in containers labeled with the name and address of Barsplice Products Inc., product name and size, heat lot number, and the ICC-ES evaluation report number (ESR-3517) and an identification code. The Zap Screwlok® Type 2 couplers are identified with the Barsplice name, the Zap Screwlok® name, the designation "Type 2", the part code designation, and a material lot code.

## 8.0 OTHER CODES

### 8.1 Evaluation Scope:

In addition to the code referenced in Section 1.0, the products described in this report were evaluated for compliance with the requirements of the 2009 *International Building Code*® (2009 IBC) and the 2006 *International Building Code*® (2006 IBC). The Zap Screwlok® Type 2 Mechanical Coupler System, as described in this report, complies with, or is a suitable alternative to what is

specified in, the 2009 and 2006 IBC, subject to the provisions of Sections 8.2 to 8.7.

### 8.2 Uses:

See Section 2.0 except as follows:

The system complies with Section 21.1.6.1 of ACI 318-08 (2009 IBC) and Section 21.2.6.1 of ACI 318-05 (2006 IBC), for use as tension and compression mechanical connections of ASTM A615 Grades 40, 60 and 75 or ASTM A706 Grade 60 deformed steel reinforcing bars. The system used to splice ASTM A615 Grade 40 and 60 bars and ASTM A706 Grade 60 bars meets requirements for Type 2 mechanical splices for use where Type 1 or Type 2 mechanical splices are specified by the IBC and ACI 318.

### 8.3 Description:

See Section 3.0

### 8.4 Design and Installation:

See Section 4.0 except as follows:

As Type 2 splices, the couplers may be installed in any location within a member, for all seismic design categories, provided the reinforcing bars are limited to Grade 40 and Grade 60 and comply with Section 21.1.5.2 of ACI 318-08 (2009 IBC) or Section 21.2.5 of ACI 318-05 (2006 IBC).

Special inspection must be provided at the jobsite as required by Section 1704 of the 2009 or 2006 IBC, as applicable. In addition to verifying placement of steel reinforcing bar splices, the special inspector must verify the grade and size of reinforcing bars; reinforcement bar embedment; coupler identification; field preparation of components; and assembly of the components resulting in the spliced bars.

### 8.5 Conditions of Use:

See Section 5.0 except as follows:

Under the 2009 IBC and 2006 IBC, for structures regulated by Chapter 21 of ACI 318 (as required by IBC Section 1908.1), to splice reinforcing bars resisting earthquake-induced flexural and axial forces in special moment frame members, special structural walls and coupling beams, with the Zap Screwlok® Type 2 Mechanical Coupler System, mill certificates for reinforcing bars must be submitted to the code official as evidence that the steel reinforcing bars comply with ACI 318-08 Section 21.1.5.2 under the 2009 IBC [ACI 318-05 Section 21.2.5 under the 2006 IBC (denoted as ACI 318 Section 21.2.5.1 in the 2006 IBC Section 1908.1.5)].

### 8.6 Evidence Submitted:

Data in accordance with the ICC-ES Acceptance Criteria for Mechanical Connector Systems for Steel Reinforcing Bars (AC133) dated December 2012 (for the 2009 IBC) and dated May 2008 (for the 2006 IBC).

### 8.7 Identification:

See Section 7.0.

TABLE 1 - DESCRIPTIVE DATA FOR ZAP SCREWLOK TYPE 2 COUPLERS

INCH SYSTEM							SI UNITS SYSTEM						
Coupler Size	Nominal Coupler Wt. (lbs.)	Coupler Length (in.)	Ave. Dimension "A" (in.)	Dimension "B" (in.)	Number of Screws per Bar	Torque (Ave.) (ft-lbs)	Bar Size	Nominal Coupler Wt. (kg)	Coupler Length (mm)	Ave. Dimension "A" (mm)	Dimension "B" (mm)	Number of Screws per Bar	Torque (Ave.) (N-m)
#4	2.2	7	1 1/16	11/16	3	50	#13	1.00	178	27	17	3	70
#5	3.4	9	1 1/8	3/4	4	50	#16	1.54	229	29	19	4	70
#6	4.7	11	1 3/16	15/16	5	50	#19	2.13	280	30	24	5	70
#7	7.6	13	1 1/4	1 1/16	5	100	#22	3.45	330	32	27	5	140
#8	10.9	15 1/4	1 5/16	1 1/16	6	100	#25	4.94	388	33	27	6	140
#9	17.6	16 3/4	1 5/8	1 1/4	6	200	#29	7.98	426	41	32	6	280
#10	21.4	19 1/8	1 11/16	1 7/16	7	200	#32	9.71	486	43	37	7	280
#11	25.4	21 1/2	1 13/16	1 1/2	8	200	#36	11.50	546	46	38	8	280
#14	31.7	15 3/8	2 5/16	1 3/4	9	350	#43	14.40	391	59	44	9	475
#18	74.0	29 1/2	2 1/2	2 1/4	21	350	#57	33.60	749	64	57	21	475

TABLE 2 - DESCRIPTIVE DATA FOR ZAP SCREWLOK TRANSITION COUPLERS

INCH SYSTEM							SI UNITS SYSTEM						
Coupler Size	Nominal Coupler Wt. (lbs.)	Coupler Length (in.)	Ave. Dimension "A" (in.)	Dimension "B" (in.)	Number of Screws per Bar	Torque (Ave.) (ft-lbs)	Bar Size	Nominal Coupler Wt. (kg)	Coupler Length (mm)	Ave. Dimension "A" (mm)	Dimension "B" (mm)	Number of Screws per Bar	Torque (Ave.) (N-m)
# 5/4	3	8	1 1/8	3/4	3	50	#16/13	1.36	203	29	19	3	70
# 6/5	4.3	10	1 3/16	15/16	4	50	#19/16	1.95	254	30	24	4	70
# 7/6	6.8	12	1 1/4	1 1/16	4	100	#22/19	3.08	305	32	27	4	140
# 8/7	9.9	14 1/8	1 5/16	1 1/8	5	100	#25/22	4.49	359	33	29	5	140
# 9/8	16.2	15 9/16	1 5/8	1 1/4	5	200	#29/25	7.35	395	41	32	5	280
# 10/9	20.1	17 15/16	1 11/16	1 7/16	6	200	#32/29	9.12	456	43	37	6	280
# 11/9	20.1	17 15/16	1 13/16	1 1/2	6	200	#36/29	9.12	456	46	38	6	280
# 11/10	22.8	20 5/16	1 13/16	1 1/2	7	200	#36/32	10.3	516	46	38	7	280

Tables 1 and 2 Note: Refer to Figure 1 for coupler Length (L), and Dimensions "A" and "B".

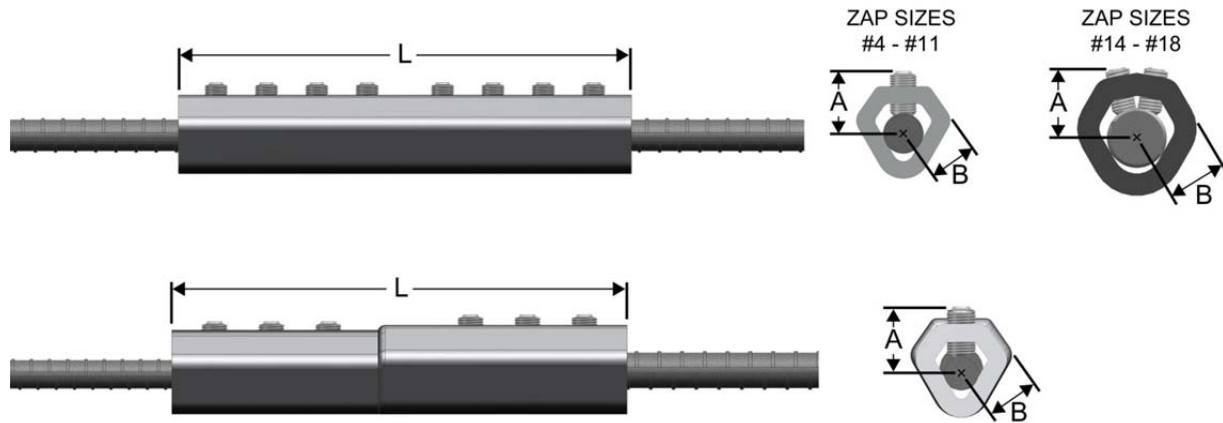

FIGURE 1—Illustration of ZAP™ Screwlok Type 2 Standard and Transition Couplers