

GRIP-TWIST® Mechanical Splices — Dimensions and Data [inch-pound units]

TAPER THREADED GRIP-TWIST

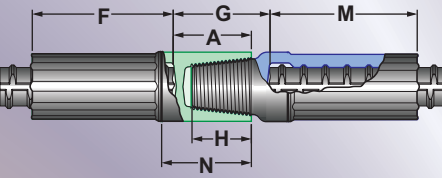

REBAR SIZE	FEMALE COUPLER PRODUCT CODE	MALE COUPLER PRODUCT CODE	TAPER GRIP-TWIST COLOR CODE	COUPLER WEIGHT (lb)		DIMENSIONS (inches)					
				FEMALE	MALE	BAR INSERTION after swaging		REBAR GAP G	MALE INSERTION H	END ALLOWANCE A	Non-Swaged LENGTH N
						F	M				
3	TT3F	TT3M	Orange	0.19	0.17	1 3/8	1 3/8	1 1/2	9/16	1	1 1/8
4	TT4F	TT4M	Pink	0.30	0.30	1 3/4	1 3/4	1 3/4	3/4	1 3/16	1 5/16
5	TT5F	TT5M	Red	0.53	0.52	2 1/4	2 3/16	1 7/8	15/16	1 3/8	1 9/16
6	TT6F	TT6M	Yellow	1.00	0.90	2 3/4	2 5/8	2 1/8	1 1/8	1 9/16	1 13/16
7	TT7F	TT7M	Blue	1.50	1.40	3 1/8	3 1/16	2 1/2	1 5/16	1 7/8	2 1/8
8	TT8F	TT8M	Black	2.10	2.00	3 9/16	3 1/2	2 7/8	1 1/2	2 1/8	2 3/8
9	TT9F	TT9M	Red	2.85	2.85	4	3 15/16	3 1/4	1 3/4	2 7/16	2 3/4
10	TT10F	TT10M	Yellow	4.05	4.00	4 1/2	4 3/8	3 5/8	2	2 3/4	3 1/8
11	TT11F	TT11M	Blue	4.90	5.00	4 7/8	4 13/16	3 1/2	2 1/8	2 3/4	3 1/8
14	TT14F	TT14M	Pink	9.05	9.10	6 1/16	5 7/8	4 3/8	2 1/2	3 5/16	3 7/8
18	TT18F	TT18M	Red	20.3	21.2	7 7/8	7 5/8	5 5/8	3 1/4	4 5/16	5 1/16

TRANSITION GRIP-TWIST

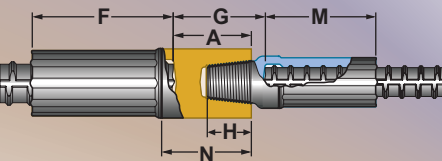

REBAR SIZE	FEMALE TRANSITION PRODUCT CODE	MALE COUPLER PRODUCT CODE	COLOR CODE		COUPLER WEIGHT (lb)		DIMENSIONS (inches)					
			TAPER FEMALE	TAPER MALE	FEMALE	MALE	BAR INSERTION after swaging		REBAR GAP G	MALE INSERTION H	END ALLOWANCE A	Non-Swaged LENGTH N
							F	M				
4/3	TT4/3F	TT3M	Pink	Orange	0.35	0.17	1 3/4	1 3/8	1 5/8	9/16	1 3/16	1 5/16
5/4	TT5/4F	TT4M	Red	Pink	0.63	0.30	2 1/4	1 3/4	1 7/8	3/4	1 3/8	1 9/16
6/4	TT6/4F	TT4M	Yellow	Pink	1.12	0.30	2 3/4	1 3/4	2 1/8	3/4	1 9/16	1 13/16
6/5	TT6/5F	TT5M		Red	1.06	0.52						
7/5	TT7/5F	TT5M	Blue	Red	1.66	0.52	3 1/8	2 3/16	2 3/8	15/16	1 7/8	2 1/8
7/6	TT7/6F	TT6M		Yellow	1.56	0.90						
8/5	TT8/5F	TT5M	Black	Red	2.51	0.52	3 9/16	2 3/16	2 5/8	1 5/8	2 1/8	2 3/8
8/6	TT8/6F	TT6M		Yellow	2.42	0.90						
8/7	TT8/7F	TT7M	Red	Blue	2.28	1.40	4	2 3/16	3	15/16	2 7/16	2 3/4
9/5	TT9/5F	TT5M		Yellow	3.52	0.52						
9/6	TT9/6F	TT6M	Red	Yellow	3.43	0.90	4	2 5/8	3	1 1/8	2 7/16	2 3/4
9/7	TT9/7F	TT7M		Blue	3.29	1.40						
9/8	TT9/8F	TT8M	Black	3.10	2.00	4 1/2	3 1/2	3 1/4	1 1/2	2 3/4	3 1/8	
10/6	TT10/6F	TT6M	Yellow	4.90	0.90							
10/7	TT10/7F	TT7M	Blue	Blue	4.77	1.40	4 1/2	3 1/16	3 3/8	1 5/16	2 3/4	3 1/8
10/8	TT10/8F	TT8M		Black	4.57	2.00						
10/9	TT10/9F	TT9M	Red	4.30	2.85	4 7/8	3 15/16	3 5/8	1 3/4	2 3/4	3 1/8	
11/7	TT11/7F	TT7M	Blue	6.05	1.40							
11/8	TT11/8F	TT8M	Black	Black	5.85	2.00	4 7/8	3 1/2	3 1/2	1 1/2	2 3/4	3 1/8
11/9	TT11/9F	TT9M		Red	5.58	2.85						
11/10	TT11/10F	TT10M	Yellow	5.24	4.00	4 1/4	4 3/8	3 3/4	2	2 13/16	3 1/4	
14/7	TT14/7F	TT7M	Blue	8.74	1.40							
14/8	TT14/8F	TT8M	Black	8.55	2.00	4 1/4	3 1/2	3 5/8	1 1/2	2 13/16	3 1/4	
14/9	TT14/9F	TT9M	Red	8.27	2.85							
14/10	TT14/10F	TT10M	Yellow	7.93	4.00	5	4 3/8	4 1/4	2	3 3/8	4	
14/11	TT14/11F	TT11M	Blue	7.56	5.00							
18/9	TT18/9F	TT9M	Red	18.2	2.85	5	4 13/16	4 1/8	2 1/8	3 3/8	4	
18/10	TT18/10F	TT10M	Yellow	17.9	4.00							
18/11	TT18/11F	TT11M	Blue	17.5	5.00							
18/14	TT18/14F	TT14M	Pink	16.4	9.10	5 7/8	4 1/2	2 1/2				

REBAR SIZE US [Metric]	COUPLER OUTSIDE DIAMETER (in.)
#3 [10]	3/4
#4 [13]	7/8
#5 [16]	1 1/8
#6 [19]	1 3/8
#7 [22]	1 9/16
#8 [25]	1 3/4
#9 [29]	1 15/16
#10 [32]	2 3/16
#11 [36]	2 3/8
#14 [43]	2 7/8
#18 [57]	3 13/16

GRIP-TWIST POSITION COUPLER

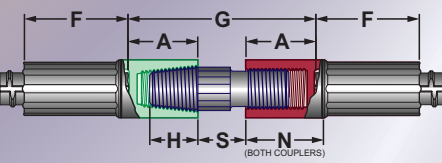

REBAR SIZE	FEMALE POSITION PRODUCT CODE	STUD PRODUCT CODE	POSITION TAPER GRIP-TWIST COLOR CODE	COUPLER WEIGHT (lb)		DIMENSIONS (inches)					
				Taper FEMALE	POSITION w/ Stud	BAR INSERTION after swaging F	REBAR GAP G	TAPER MALE INSERTION H	END ALLOWANCE A	Non-Swaged LENGTH N	SPACE after assembly S
5	5PF	TT5RP	Red	0.53	0.90	2 1/4	3 7/8	15/16	1 3/8	1 9/16	1 1/8
6	6PF	TT6RP	Yellow	1.00	1.60	2 3/4	4 3/8	1 1/8	1 9/16	1 13/16	1 1/4
7	7PF	TT7RP	Blue	1.50	2.55	3 1/8	5 3/8	1 9/16	1 7/8	2 1/8	1 5/8
8	8PF	TT8RP	Black	2.10	3.45	3 9/16	5 3/4	1 1/2	2 1/8	2 3/8	1 1/2
9	9PF	TT9RP	Red	2.85	4.85	4	6 1/2	1 3/4	2 7/16	2 3/4	1 5/8
10	10PF	TT10RP	Yellow	4.05	6.95	4 1/2	7 3/8	2	2 3/4	3 1/8	1 7/8
11	11PF	TT11RP	Blue	4.90	8.80	4 7/8	7 1/4	2 1/8	2 3/4	3 1/8	1 3/4
14	14PF	TT14RP	Pink	9.05	15.3	6 1/16	8 3/4	2 1/2	3 5/16	3 7/8	2 1/8
18	18PF	TT18RP	Red	20.3	34.3	7 7/8	10 3/4	3 1/4	4 5/16	5 1/16	2 1/8

GRIP-TWIST FLANGED COUPLER

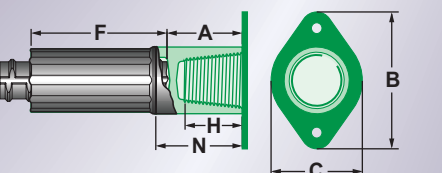

REBAR SIZE	FEMALE FLANGED PRODUCT CODE	TAPER GRIP-TWIST COLOR CODE	FEMALE COUPLER PLUS FLANGE WEIGHT (lb)	DIMENSIONS (inches)					
				BAR INSERTION after swaging F	FLANGE HEIGHT B	FLANGE WIDTH C	MALE INSERTION H	END ALLOWANCE A	Non-Swaged LENGTH N
4	TT4FWFL	Pink	0.33	1 3/4	1 15/16	1 3/8	3/4	1 3/16	1 5/16
5	TT5FWFL	Red	0.58	2 1/4	2 3/8	1 5/8	15/16	1 3/8	1 9/16
6	TT6FWFL	Yellow	1.05	2 3/4	2 3/4	1 7/8	1 1/8	1 9/16	1 13/16
7	TT7FWFL	Blue	1.56	3 1/8	2 15/16	2 1/16	1 5/16	1 7/8	2 1/8
8	TT8FWFL	Black	2.17	3 9/16	3 1/4	2 1/4	1 1/2	2 1/8	2 3/8
9	TT9FWFL	Red	2.92	4	3 7/16	2 3/8	1 3/4	2 7/16	2 3/4
10	TT10FWFL	Yellow	4.14	4 1/2	3 11/16	2 5/8	2	2 3/4	3 1/8
11	TT11FWFL	Blue	5.00	4 7/8	3 3/4	2 3/4	2 1/8	2 3/4	3 1/8

GRIP-TWIST® Mechanical Anchorage — Dimensions and Data [inch-pound units]

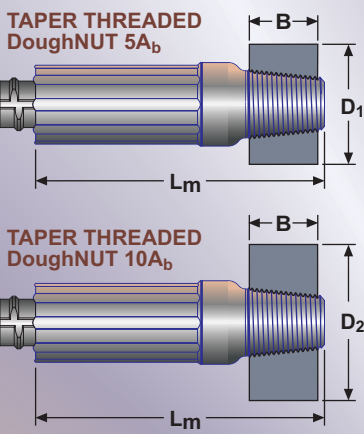

Rebar Size US [Metric]	Male Coupler Product Code	TDS Head Product Code	TDX Head Product Code	Male Swaged Length Lm (in.)	Thickness B (in.)	Head Diameter and Weight *		Head Diameter and Weight **	
						TDS Series [5Ab]		TDX Series [10Ab]	
						D1 (in.)	Wt (lb.)	D2 (in.)	Wt (lb.)
#4 [13]	TT4M	4TDS	4TDX	2 15/16	5/8	1 1/4	0.17	1 3/4	0.38
#5 [16]	TT5M	5TDS	5TDX	3 5/8	3/4	1 1/2	0.29	2	0.58
#6 [19]	TT6M	6TDS	6TDX	4 5/16	15/16	1 3/4	0.47	2 1/2	1.14
#7 [22]	TT7M	7TDS	7TDX	5	1 1/8	2	0.73	3	1.98
#8 [25]	TT8M	8TDS	8TDX	5 11/16	1 1/4	2 1/4	1.03	3 1/4	2.56
#9 [29]	TT9M	9TDS	9TDX	6 1/2	1 1/2	2 3/4	1.93	3 3/4	4.10
#10 [32]	TT10M	10TDS	10TDX	7 1/4	1 5/8	3	2.44	4	4.97
#11 [36]	TT11M	11TDS	11TDX	7 5/8	1 3/4	3 1/4	3.03	4 1/2	6.80
#14 [43]	TT14M	14TDS	14TDX	9 3/8	2 1/8	3 3/4	4.71	5 1/2	12.4
#18 [57]	TT18M	18TDS	18TDX	12 3/16	2 3/4	5	10.9	7 1/4	27.8

* Head Cross Sectional Area is approximately 5 x Rebar Area ** Head Cross Sectional Area is approximately 10 x Rebar Area

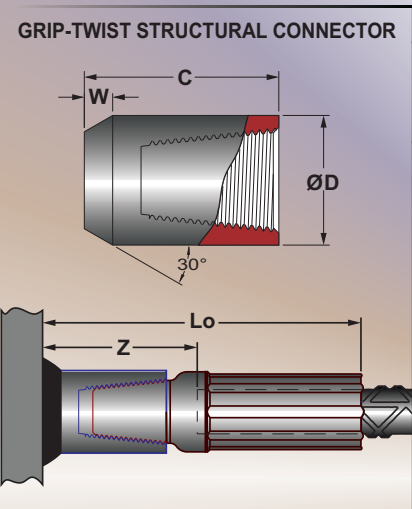

Rebar Size US [Metric]	Structural Connector Product Code	Taper Grip-Twist Color Code	Structural Connector Weight (lbs.)	DIMENSIONS (inches)					
				Structural Connector Outside Dia. D	Structural Connector Length C	Weld Bevel Length W	Gap Z	Overall Length Lo	
#4 [13]	TT4SC	Pink	0.15	7/8	1 3/8	3/16	1 3/4	3 1/2	
#5 [16]	TT5SC	Red	0.30	1 1/8	1 11/16	1/4	2 1/8	4 5/16	
#6 [19]	TT6SC	Yellow	0.60	1 3/8	2	1/4	2 1/2	5 1/8	
#7 [22]	TT7SC	Blue	0.85	1 9/16	2 5/16	5/16	2 15/16	6	
#8 [25]	TT8SC	Black	1.15	1 3/4	2 5/8	3/8	3 5/16	6 13/16	
#9 [29]	TT9SC	Red	1.60	1 15/16	3	7/16	3 13/16	7 3/4	
#10 [32]	TT10SC	Yellow	2.25	2 3/16	3 3/8	1/2	4 3/16	8 9/16	
#11 [36]	TT11SC	Blue	2.75	2 3/8	3 9/16	9/16	4 1/2	9 3/8	
#14 [43]	TT14SC	Pink	5.05	2 7/8	4 3/8	11/16	5 3/8	11 1/4	
#18 [57]	TT18SC	Red	11.75	3 13/16	5 3/4	7/8	7 1/16	14 11/16	

GRIP-TWIST® — Equipment and Installation

A Bench Press BP2600 fitted with a two-piece die set and powered by an electrically-driven hydraulic pump is used by the rebar fabricator to efficiently swage Grip-Twist® coupler components. The equipment operator depresses a foot control to actuate the system. As the ram extends and pushes the dies towards each other, the coupler component is forced to deform around the rebar and interlock with the bar profile. When a swaging bite has been completed, a pressure switch automatically stops the process and the operator retracts the ram for the next bite. For ease of use, swaging dies are color coded and stamped with a serial number that indicates the rebar and coupler size. Color codes are shown on Grip-Twist® Dimensions and Data Charts. *NOTE: In lieu of shop installation, it may sometimes be appropriate to use BPI-Grip field-swaging equipment such as press models BG1140M or BG750M - contact BPI for assistance with your application.*

BP2600

Bench press for swaging all sizes up to No. 18 (Ø 57mm).
Double acting cylinder produces 300 tons of force
connected to 10 or 15 hp pump for high fabrication shop
productivity - includes foot control, lifting eyes and leveling
feet - weighs 1,600 lbs [725 kg].

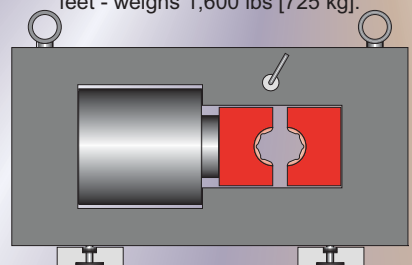

BPI®
Equipment is available for lease or purchase. Equipment must be used in accordance with manuals, lease agreements, manufacturers' directions and all safety instructions.



While the information contained in this document is believed to be accurate at the time of publication, BPI reserves the right to make changes, design modifications, corrections and other revisions as it sees fit, without notice. All products described herein are supplied in accordance with BPI's standard Terms and Conditions of Sale. This document is of a promotional nature only. Aspects of structural design, evaluation of product fitness for use, suitability or similar attributes are the responsibility of others.



BarSplice Products, Inc., 4900 Webster Street, Dayton OH 45414, USA
● Tel: (937) 275-8700 ● Fax: (937) 275-9566 ● E-mail: bar@barsplice.com



REV.F 5/13/2011