

BPI-GRIP™ SYSTEM — Dimensions and Data [metric units]

BARGRIP

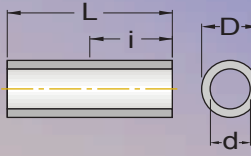

BPI® Coupler Size	Product Code	Length 'L' (mm)	Coupler Weight (kg)	Color Code	Rebar Size	Outside Dia. 'D' (mm)	Inside Dia. 'd' (mm)	Insertion Bar 'i' (mm)	Press Model	'H' (mm)	'S' (mm)	'T' (mm)	'X' (mm)	'U' (mm)	No. Bites
3	3BG	51	0.07	Orange	10mm	19	13	25	BG 250	67	41	51	102	57	3
4	4BG	64	0.11	Pink	12mm	24	16	32		76	44	54	108	60	4
5	5BG	79	0.21	Red	16mm	29	19	40		86	48	57	149	64	6
6	6BG	95	0.39	Yellow	20mm	35	24	48	BG 400	121	76	108	171	133	5
7	7BG	111	0.56	Blue	22mm	40	27	56		133	76	114	197	140	7
8	8BG	127	0.83	Black	25mm	44	30	64		146	83	114	216	140	9
9	9BG	140	1.10	Red	29mm	49	35	70	BG 750M	165	83	133	267	159	7
10	10BG	160	1.57	Yellow	32mm	56	38	79		178	89	140	292	165	9
11	11BG	175	1.99	Blue	36mm	60	43	87		191	89	146	305	165	12
12	12BG	190	2.85	Brown	38mm	68	46	95	BG1140M	215	117	174	320	225	9
13	13BG	200	3.35	Black	40mm	70	47	100		225	118	176	336	226	9
14	14BG	222	4.30	Pink	43mm	75	50	111		235	121	178	356	229	11
16	16BG	260	6.25	Gray	50mm	86	59	130		270	127	191	445	235	16
18	18BG	305	9.34	Red	57mm	97	67	152		305	133	203	502	241	21

BARGRIP XL

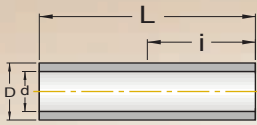

3	3XL	83	0.12	Orange	10mm	19	13	41	BG 250	83	41	51	117	57	5
4	4XL	102	0.18	Pink	12mm	24	16	51		95	44	54	127	60	7
5	5XL	121	0.31	Red	16mm	29	19	60		108	48	57	171	64	9
6	6XL	140	0.57	Yellow	20mm	35	24	70	BG 400	143	76	108	194	133	9
7	7XL	159	0.80	Blue	22mm	40	27	79		159	76	114	222	140	11
8	8XL	178	1.17	Black	25mm	44	30	89		171	83	114	241	140	14
9	9XL	191	1.50	Red	29mm	49	35	95	BG 750M	191	83	133	292	159	8
10	10XL	210	2.05	Yellow	32mm	56	38	105		203	89	140	318	165	11
11	11XL	229	2.60	Blue	36mm	60	43	114		219	89	146	333	165	14
12	12XL	248	3.70	Brown	38mm	68	46	124	BG1140M	244	117	174	349	225	11
13	13XL	260	4.75	Black	40mm	70	47	130		255	118	176	366	226	12
14	14XL	279	5.40	Pink	43mm	75	50	140		264	121	178	385	229	14
16	16XL	320	7.50	Gray	50mm	86	59	160		300	127	191	475	235	20
18	18XL	356	10.9	Red	57mm	97	67	178		330	133	203	528	241	25

BARGRIP XL TRANSITION

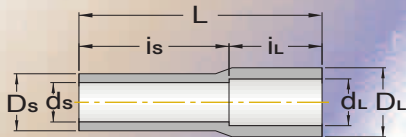

BPI® Coupler Size	Product Code	Color Code	Length 'L' (mm)	Coupler Weight (kg)	Rebar Insertion 'iL' 'is' (mm)		Outside Diameter 'DL' 'Ds' (mm)		Inside Diameter 'dL' 'ds' (mm)	
5/4	5/4XL	See BarGrip Color Code above	88	0.17	35	55	27	22	19	16
6/5	6/5XL		104	0.33	40	64	35	27	24	19
7/6	7/6XL		121	0.55	52	68	40	35	27	24
8/6	8/6XL		137	0.78	64	73	44	35	30	24
8/7	8/7XL		137	0.80	64	73	44	40	30	27
9/8	9/8XL		156	1.14	73	83	49	44	33	30
10/8	10/8XL		175	1.59	75	100	56	44	38	30
10/9	10/9XL		175	1.60	78	97	56	49	38	33
11/9	11/9XL		185	1.79	80	105	60	49	41	33
11/10	11/10XL		185	1.99	83	102	60	56	41	38
12/10	12/10XL		197	2.37	83	114	67	56	46	38
13/10	13/10XL		210	2.77	92	117	70	56	46	38
14/11	14/11XL		226	3.20	92	134	73	60	49	41
18/14	18/14XL		294	5.76	111	183	86	73	67	49

SIDE VIEW DOUBLE ROW

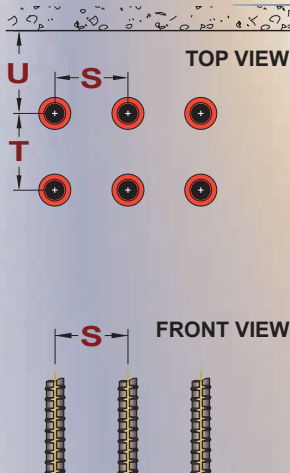
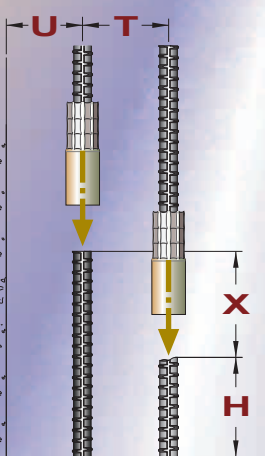

BARGRIP STRUCTURAL CONNECTOR

Structural Connector Size	Product Code	SC Length 'L' (mm)	SC Weight (kg)	Minimum Insertion * 'i' (mm)	Weld Bevel Length 'W' (mm)
3	3LB	95	0.14	25	5
4	4LB	102	0.18	32	5
5	5LB	108	0.29	41	6
6	6LB	114	0.46	48	6
7	7LB	127	0.64	57	8
8	8LB	152	1.00	64	10
9	9LB	165	1.29	70	11
10	10LB	178	1.74	79	13
11	11LB	191	2.16	89	14
12	12LB	200	2.78	97	15
13	13LB	213	3.45	102	16
14	14LB	222	4.29	114	17
16	16LB	260	6.05	133	19
18	18LB	305	9.34	156	22

NOTES: For each bar size, Color Code, Outside Diameter, Inside Diameter and 'S' Dimension are the same as for BarGrip above.
 * Minimum Rebar Insertion equals the swage length. Maximum Rebar Insertion equals the coupler length.

BG400

COMPACT FIELD PRESS

25 kg

mostly used on 20, 22, 25 mm bar

BPI® COUPLER SIZES

Ø10 - Ø25mm



BG750M

MIDSIZE FIELD PRESS

40 kg

mostly used on

25, 29, 32, 36 mm bar

BPI® COUPLER SIZES

Ø16 - Ø36mm

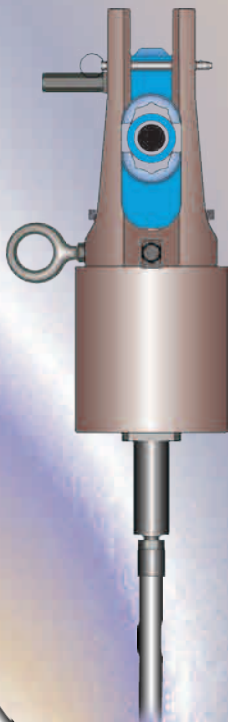

BG1140M

HEAVY-DUTY

FIELD PRESS

94 kg

mostly used on

32, 36, 43, 57 mm bar

BPI® COUPLER SIZES

Ø22 - Ø57mm

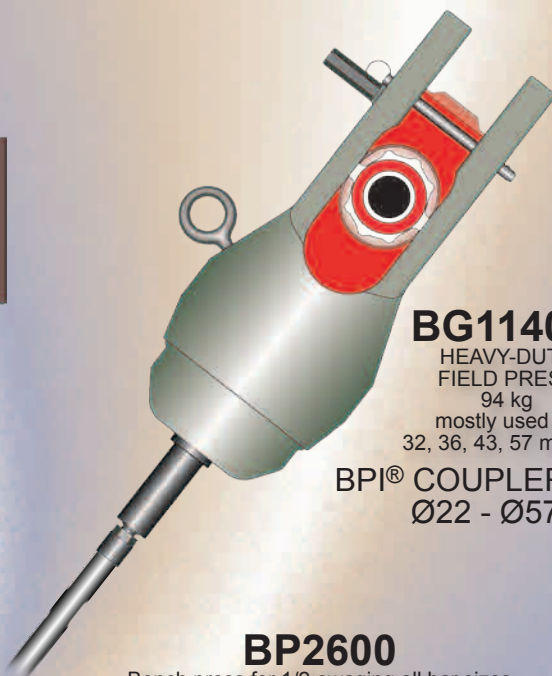

BG250

MINI FIELD PRESS

9 kg

mostly used on 13, 16 mm bar

BPI® COUPLER SIZES

Ø10 - Ø20mm

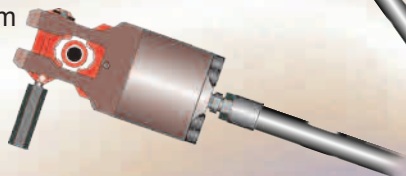

BP2600

Bench press for 1/2-swaging all bar sizes up to 57mm. Double acting cylinder connected to 10 or 15 hp pump for high fabrication shop productivity - includes foot control, lifting eyes and leveling feet - weighs 725 kg.

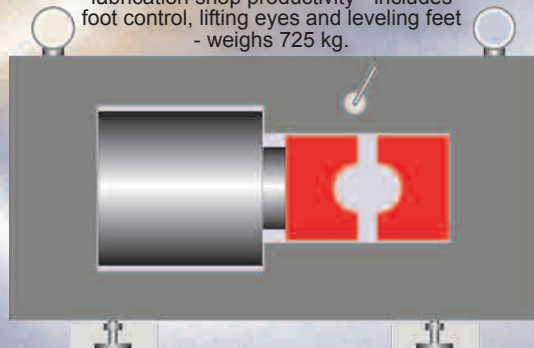

BPI® COUPLER SIZES

Ø10 - Ø57mm

BPI® swaging equipment for the installation of coupling sleeves and connectors consists of a hydraulic **PRESS**, **PUMP** and **HOSE** with suitable swaging **DIES**.

Press models for field swaging range in size from the BG 250 for splicing #3 - 6 rebars (Ø10 - 20 mm), to the BG 1140M for splicing bars up to #18 (Ø57 mm). Each press is provided with a lifting handle and/or lifting eye for support. By a simple change of die set, each press is capable of swaging multiple sizes of coupling sleeve inclusive of BarGrip - XL - UXL - Transitions and Structural Connectors. For ease of use, dies and coupling sleeves are stamped and color-coded to match.

A hydraulic pump, electrically-driven or gasoline-driven, connects to the press by means of a hose with quick-disconnect ends. The equipment operator depresses a foot control to actuate the system. As the ram of the press extends and pushes the dies towards each other, a portion of the coupling sleeve is forced to deform around the rebar and interlock with the bar profile. When each swaging bite has been completed, a pressure switch built into the pump, automatically stops the process to allow the ram of the press to retract for the next bite. *After a coupling sleeve has been fully swaged, the operator simply slides the outer die out of the press for convenient removal of the press from around the spliced rebar.*

A Bench Press can be utilized by the rebar fabricator to efficiently 1/2-swage coupling sleeves to rebars ahead of shipping, thereby saving time on the jobsite.

NOTE: In lieu of shop 1/2-swaging with a Bench Press, it may sometimes be appropriate to use a field press such as a BG1140M or BG750M - contact BPI for assistance with your application.

BPI® Equipment is available for lease or purchase. Equipment must be used in accordance with manuals, lease agreements, manufacturers' directions and all safety instructions.

Pump Model	PE 55	PE 400	PG 400
Driver	1 1/2 HP Electric Motor	10 HP Electric Motor	18 HP Gasoline Engine
Power Supply	115V 1-phase	230V or 460V 3-phase	Battery Start
Weight with fluid	66 kg	274 kg	247 kg
Most common use	Rebar Ø10-36mm	Rebar Ø28-57mm	Rebar Ø28-57mm
Attributes	Compact / Maneuverable	Fast / High volume jobs	No power supply required

While the information contained in this document is believed to be accurate at the time of publication, BPI reserves the right to make changes, design modifications, corrections and other revisions as it sees fit, without notice. All products described herein are supplied in accordance with BPI's standard Terms and Conditions of Sale. This document is of a promotional nature only. Aspects of structural design, evaluation of product fitness for use, suitability or similar attributes are the responsibility of others.



MEMBER

BarSplice Products, Inc., 4900 Webster Street, Dayton OH 45414, USA
 ●Tel: (937) 275-8700 ●Fax: (937) 275-9566 ●E-mail: bar@barsplice.com



MEMBER